

AUTOMATIC RAILROAD CROSSING CONTROLLER

USER GUIDE

RELEASE 1.1

Copyright © 2001 by JT Chamberlain

CONTENTS

- 1 OPERATION**
- 2 DUAL TRACK WORKING**
- 3 SENSOR MOUNTING & ALIGNMENT**
- 4 CONNECTIONS**
 - 4.1 Single-Track Operation**
 - 4.2 Dual-Track Operation**
 - 4.3 Sensor Cable Connections**
- 5 CIRCUIT DIAGRAM**
- 6 CIRCUIT BOARD CONSTRUCTION**

DISCLAIMER

I hope you will like the ARCC and enjoy using it as much as I have enjoyed creating it, BUT .
..

While every effort has been made to thoroughly test and verify all functions incorporated into the ARCC hardware, please note that it is supplied on an "as is" basis and without warranty of any kind. You use the ARCC hardware items at your own risk. The author and designer will not in any event be held liable for any improper operation of the ARCC system or interference with any other equipment, nor be held liable for any incidental or consequential damages of any sort arising out of its use.

Note that the ARCC is supplied as a bare circuit board and should be handled with care. Avoid flexing the board unnecessarily, especially when attaching cables to the various header connectors, and ensure that no part of the ARCC is short-circuited to adjacent metal objects or wires.

The circuitry of the ARCC is sensitive to damage from electrostatic discharge. Observe proper electrostatic precautions when handling the unit and its connecting cables. The use of a properly-grounded wriststrap is highly recommended.

1 OPERATION

The Automatic Railroad Crossing Controller (ARCC) is designed to operate signals and/or barriers as a train approaches a crossing, and then switch the signals off (and raise any barriers) once the end of the train is clear of the crossing.

The system works by having four infra-red light beams across the track, as shown in Figure 1. The source of each infra-red beam is a suitable LED, positioned on one side of the track, and its light is detected on the opposite side of the track by a matching phototransistor. Each of the four beams will be broken in sequence by the train as it travels along the track and over the crossing.

If a train is approaching from the left, for example, the crossing signals, etc., are activated as the front of the train (locomotive) breaks beam 'A'. The signals stay activated until the last car in the train has passed through beam 'C', and the beam is intact again. Similarly, for a train approaching from the right, the crossing signals are activated as beam 'D' is broken, and continue until the complete train has passed through beam 'B'.

It is important to appreciate that all four beams are broken as the train moves through. When travelling from left to right, breaking beam 'B' before beam 'D' effectively tells the ARCC to ignore the breaking of beam 'D' until the train has passed completely through the set of sensors, ie. until the last car has travelled beyond beam 'D'. The ARCC is then returned to its "Ready" state, where the breaking of either beam 'A' or 'D' will trigger the crossing signals. A similar sequence applies for trains travelling from right to left, where the breaking of beam 'C' stops the ARCC from re-triggering the crossing signals as soon as beam 'A' is broken.

One consequence of this mode of operation is that it is possible to confuse the ARCC by stopping and reversing the train while it is within the sensor area, ie. positioned anywhere between beams 'A' and 'D'. The usual result is that the ARCC "sticks" in the state it was in when the train stopped. Normal operation can usually be restored by running the train forward again until it is completely beyond the sensor area, then reversing it back through all of the beams - at which point the ARCC should resume its "Ready" state with the crossing signals inactive. If this fails, then there is a 'Reset' pushbutton fitted to the ARCC which, when operated, will sort out the mess.

2 DUAL TRACK WORKING

The ARCC is designed to handle only a single track, but it is possible to handle a railroad crossing with dual tracks, by fitting a second ARCC module, with its own set of four infra-red beam sensors. The two ARCCs are coupled together so that a train running in either direction, on either track, will operate the crossing signals. If you have trains running across the crossing on both tracks simultaneously, then the first train to reach an 'outer' sensor (its own 'A' or 'D') will activate the crossing signals/barriers. These will stay active until BOTH trains are clear of their own inner sensors (the relevant 'B' or 'C').

Again, you can confuse the ARCCs by stopping and reversing a train on either track while within the sensor area - the best course of action is not to do it!

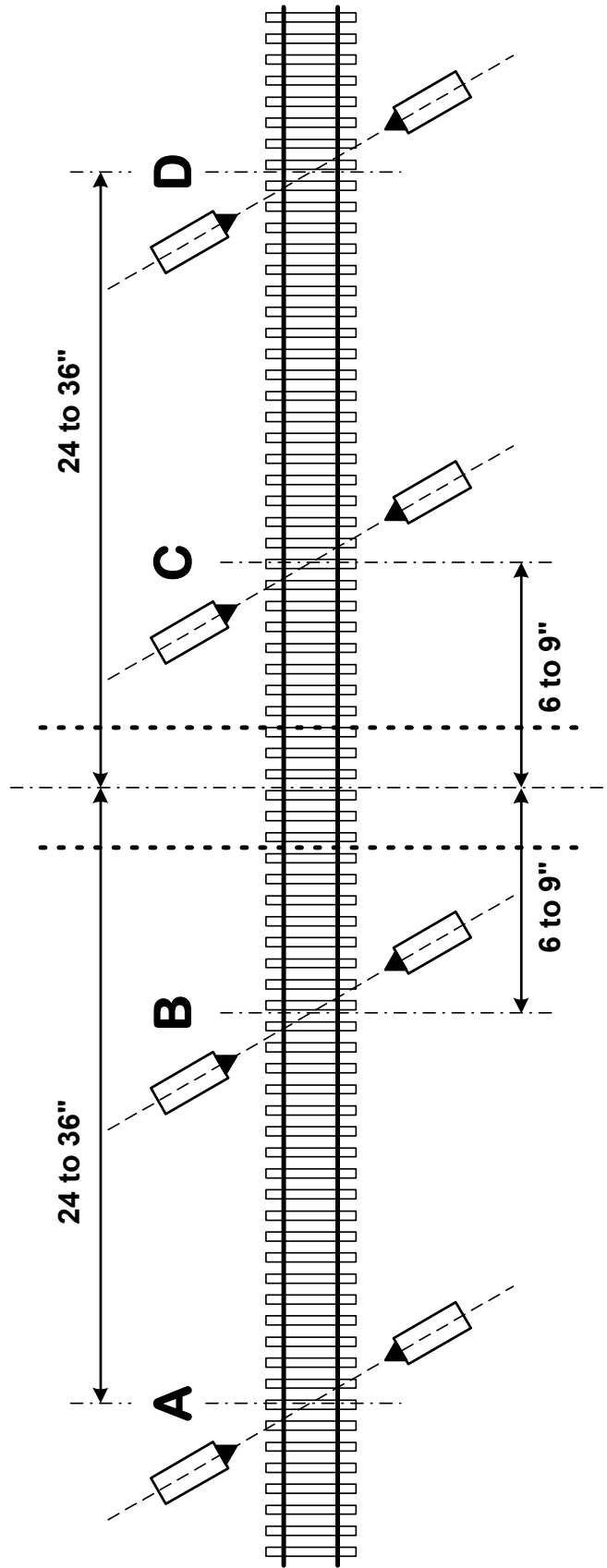

Figure 1

Automatic Railroad Crossing Controller - Position of Across-Track Sensors

NOT TO SCALE

3 SENSOR MOUNTING & ALIGNMENT

Both the LED infra-red source and phototransistor detector are in standard T1 packages, 3mm in diameter. They are each mounted at one end of a short length of aluminium tubing (1/8in internal diameter by 3/4in long) to exclude interference from external lighting. The sensor pair are then carefully aligned, facing each other, on opposite sides of the track. If space is limited, the tubing could be cut down to, say, 1/2in long.

In all cases, each sensor pair should be positioned in accordance with NMRA standard track clearances (S-7 Clearances). For HO scale this means that no part of the sensor assemblies should be closer than 26.2mm to the track centre line (although this could be reduced to 20.6mm on straight lengths of track).

Each sensor pair is supplied ready wired to a 48in length of 4-core cable fitted with a plug to connect to the ARCC unit (see section 4 below), and with a pair of supporting plastic blocks. These blocks are made by NETLON, and are actually intended for some purpose in the garden or greenhouse but, for initial trials at least, they are a convenient means of supporting the sensors on either side of the track. There is probably no way the blocks could be disguised as scale trackside objects, but it is assumed that, ultimately, the sensors will be built into the layout landscaping or buildings. Details of the blocks are shown in Figure 2 below.

Figure 2

Sensor Mounting in Block

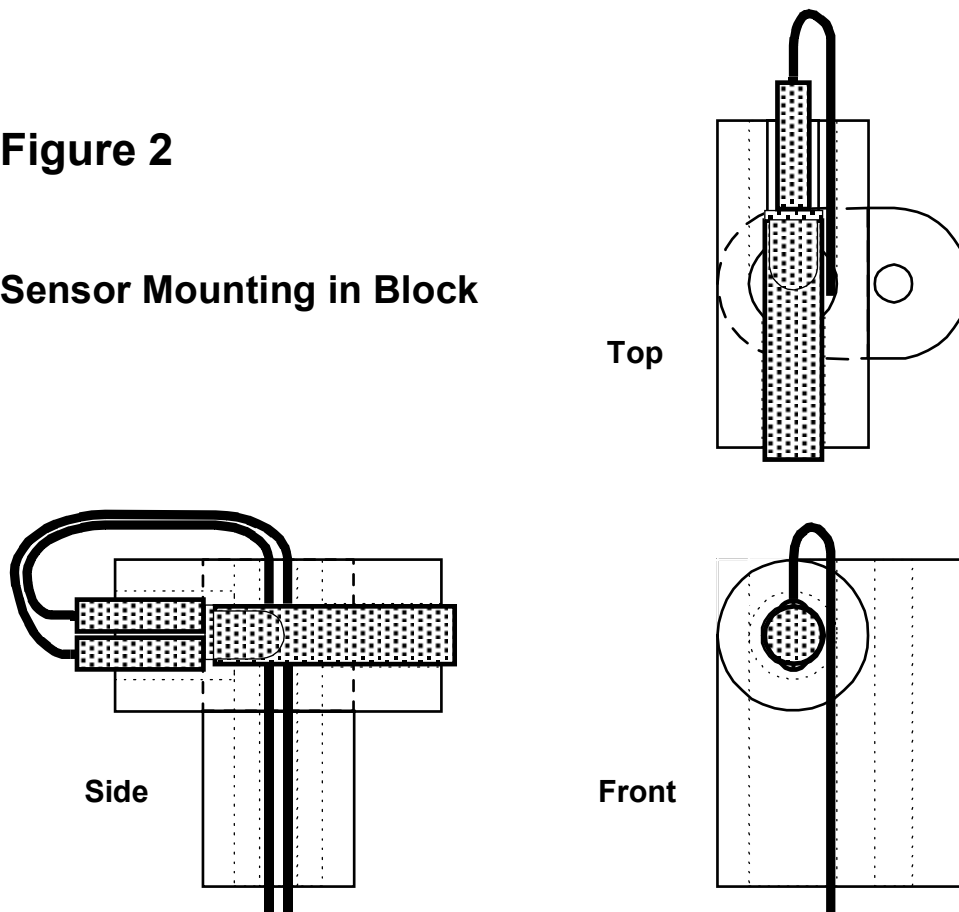

The end of the horizontal section holding the sensor shielding tube is drilled out to 5mm diameter, and the other end, where the LED or phototransistor is connected to the cable, is drilled out to 7mm diameter. The vertical hole below the sensor assembly is also made 7mm in diameter so that the LED or phototransistor assembly can be passed through the block from below (via a suitable hole in the baseboard) before being positioned in the block's horizontal

section. This keeps the ARCC wiring reasonably tidy. The smaller, 3mm diameter, vertical hole in the block is used to secure it to the baseboard using a suitable screw or bolt.

The sensor pair should be angled across the track, as shown in Figure 1, so that the ARCC does not “see” the inter-car gaps, ie. the beam stays broken for the complete length of the train. The angle is not critical (and does not have to be the same for each sensor pair) but should be at least 60 degrees for normal HO scale. The sensors will operate reliably over separations between LED and detector of at least 125mm (90mm between the ends of the shielding tubes) so that an angle of 45 degrees can be accommodated (as required for UK 00 scale, for example).

The really critical mounting dimension is the height of the beams. Each sensor pair must be positioned so that the beam is completely broken by each locomotive and car in the train for the total length of the train. If a beam can pass through some gap in the car structure, then the ARCC is liable to get a false indication that the end of the train has been detected, and the crossing signals will be switched off prematurely. The crossing signals can also be re-activated as the train continues through, leading to erratic, non-realistic operation.

The optimum height setting is as shown in Figure 3, with the beams positioned 13mm (± 1 mm) above top-of-rail, just below the floor level of each car. This is not absolutely foolproof as empty flat cars with a depressed loading platform, or some hopper cars with an open end-structure, can allow the beams to become re-established momentarily. If you wish to run trains through the crossing with these types of cars, then it may be necessary to angle the sensor pairs downwards, as well as across the track, for example, to ensure 100% interruption of the beams by the available structure of the cars. A simpler alternative might be to modify the problem cars in some fashion to block the offending gaps - if this can be done without major departures from prototype scale.

The plastic supporting blocks, as supplied, raise the sensor height to 20mm above the baseboard. Hence, if top-of-rail is less than 7mm above the baseboard, the blocks should be cut down to the appropriate height. Guide lines 3mm and 6mm from the base of each block have been scribed on to assist in cutting the blocks square.

Once the two parts of the sensor pair are mounted on opposite sides of the track they should be carefully aligned. This can be done well enough by eye, but you can use a straight rod or bar laid in the grooves on top of the plastic blocks as an aid.

A final check on sensor alignment can be done with the ARCC powered on, and using a high-impedance voltmeter to measure the voltage at the collector of each detector (at the base of Q2, Q4, Q6, or Q8 - see the attached circuit and board layout diagrams). The voltage level should be around 0.2 volts - and definitely less than 0.5 volts. Adjust the sensor alignment for a minimum value.

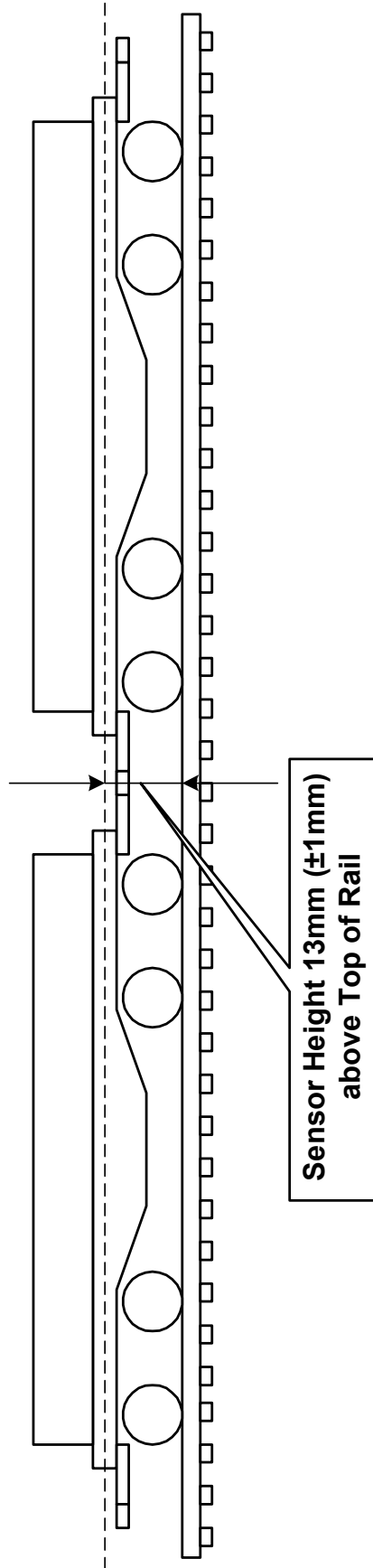

Automatic Railroad Crossing Controller - Height of Across-Track Sensors

Figure 3

4 CONNECTIONS

4.1 Single-Track Operation

In its simplest configuration, the ARCC has connections to each of the four sensor pairs, to a source of power, and an output connection to the crossing signals and/or barriers. The position of these connections on the ARCC unit are shown in Figure 4. The two large heatsinks fitted to the ARCC are for the 5 volt regulator (on the left) and for the output transistor which drives the crossing signals and/or barriers. Mount the ARCC so that they have a reasonable airflow over them (**NOT** in a small, sealed box!). The regulator heatsink will normally run warm to the touch, but that for the output driver will only get hot if it is asked to provide maximum output (1 Amp) for an extended period - not a usual operating scenario.

External power is connected to the outer terminals of the terminal block located at the bottom left of the ARCC circuit board. This is normally 12 volts AC, but a DC supply can be used if preferred. The polarity applied does not matter, but the supply should be at least 14 volts to compensate for the voltage drop across the input bridge rectifier. Supply voltages higher than this should be avoided since they only cause the 5 volt regulator to run much hotter. The ARCC can also be powered directly from the track during DCC operation (a 14 volt peak AC square waveform).

The DC voltage available to the output circuitry depends on the source of external power. With normal 12 VAC it will be around 16 volts, with external DC supplied it will be about 2 volts lower than the input voltage, and DCC will give around 12 volts.

Note that the external supply to the ARCC must be capable of providing the current required by whatever is connected to the output, up to the maximum allowable value of 1 Amp. Drawing a high current from the track DCC supply will reduce the number of locomotives you can run simultaneously in that power district.

Handle the ARCC circuit board with care. Avoid flexing the board unnecessarily, especially when attaching cables to the various header connectors, and ensure that no part of the ARCC is short-circuited to adjacent metal objects or wires.

The circuitry of the ARCC is sensitive to damage from electrostatic discharge. Observe proper electrostatic precautions when handling the unit and its connecting cables. The use of a properly-grounded wriststrap is highly recommended.

The four sensor cables are plugged into the appropriate headers on the ARCC - these are clearly labelled on the ARCC itself - after the sensor pairs have been mounted across the track in the required positions.

To remove cables from the headers, gently pull the upright plastic part of the header away from the plug body with one hand, grip the plug body with the other, and pull the plug straight upwards. Do not try to disconnect by pulling on the cable, and take care not to bend the header pins.

When the ARCC is powered on, it should automatically reset itself to the “Ready” state. If, for some reason this does not happen, then there is a Reset pushbutton on the board for this purpose (to the left of the regulator heatsink). For convenience it is also possible to connect a remote ‘push-to-make’ pushbutton to the Remote Reset terminals. There is no restriction on the length of wire to such a remote pushbutton, so that it can be mounted wherever necessary on the layout, and you could even have several pushbuttons connected in parallel.

When the crossing is triggered by a train breaking beams ‘A’ or ‘D’, the green Crossing Active LED at the right-hand end of the ARCC will light, showing that the output driver has been switched on.

Connect the supplied lead (Yellow/Brown) to the 2-pin Power Output header next to the output driver heatsink and to either the crossing signals/barriers directly, or via a relay. Be sure to observe the correct polarity when connecting directly - Yellow is connected to the ARCC +12 volt DC line, and Brown to the collector of the output transistor. When active, the Brown connection will be close to Ground (0 volts), at low currents, rising to about +1 volts at the maximum 1 Amp output load. A diode is fitted to the ARCC to protect the output transistor from back-EMF surges when a relay is connected.

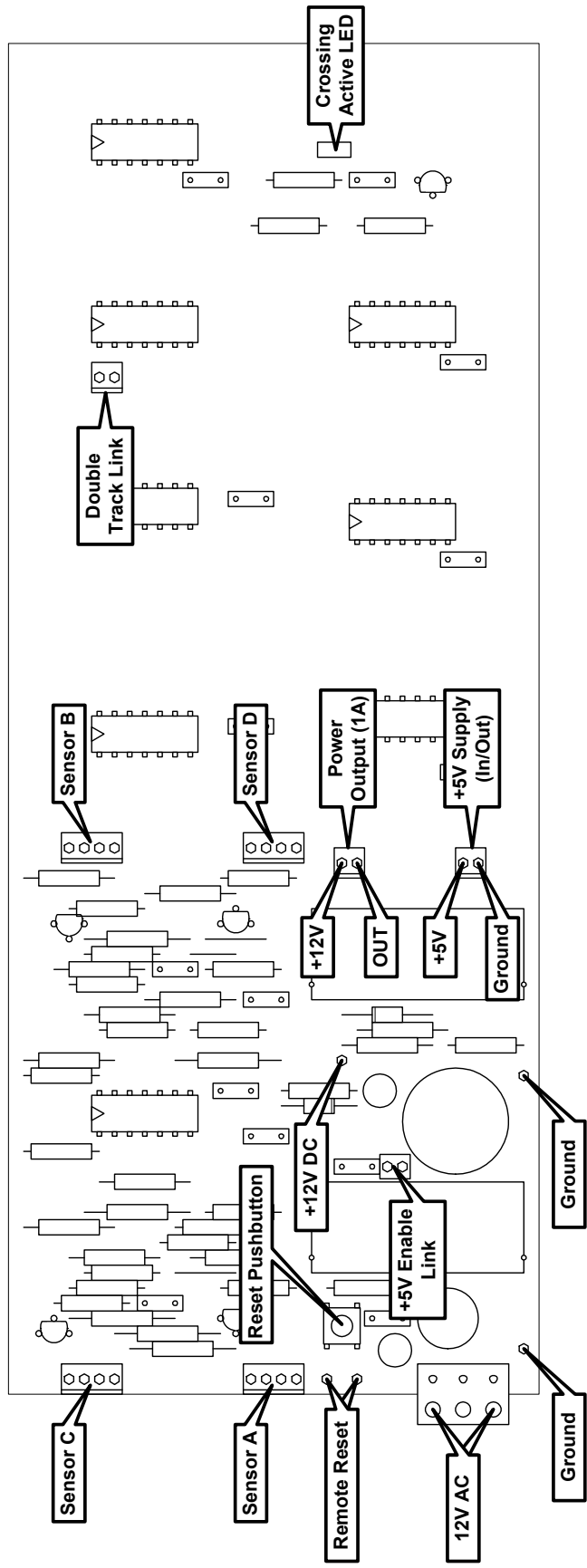

Figure 4

Automatic Railroad Crossing Controller - Location of Connectors and Features

4.2 Dual-Track Operation

Two ARCCs can be used together to operate a dual-track crossing. In this case power only needs to be supplied to one ARCC. Power is supplied to the second ARCC via the required cross-connections.

On the second ARCC, locate the +5V Enable Link fitted to the right of the regulator heatsink, and remove it. This disconnects the regulator from the rest of the ARCC circuitry, and prevents it being damaged by the +5V supply from the first ARCC.

Now connect the supplied Red/Blue lead between the +5V Supply (In/Out) 2-pin headers on each ARCC. The connectors are polarised so it should not be possible to connect it the wrong way round - Red is +5V, Blue is Ground. Take care to connect to the correct headers - those closest to the bottom edge of each ARCC circuit board.

Next locate and remove the Double Track Link, fitted at the top right-hand corner of each ARCC circuit board, from the 2-pin headers, and fit the supplied Pink/Grey lead between the headers. Note that the pairs of pins are cross-connected, unlike the power supply lead - take care that you do not get these two leads mixed up - the Double Track Link lead is made with wires of a much smaller gauge.

Connect the output drive from the first ARCC (the one connected to the external power source) to the crossing signals/barriers, and connect up the two sets of four sensors to their respective ARCCs. Note that, when the crossing is activated by a train on either track, the Crossing Active LEDs on both ARCCs will light, regardless of which was triggered, and will remain on until both tracks are again clear in the sensor areas.

The reset circuitry on each ARCC remains independent. Resetting one with its onboard pushbutton has no effect on the other. However, it is permissible to wire the two Remote Reset connections together (taking care to wire the corresponding pins together, and not get them cross-linked) so that either pushbutton will reset both ARCCs. You can also wire the linked Remote Reset pins to a single remote pushbutton for greater convenience.

If, for some reason, you require two output drives, it is possible to connect the second ARCC to an external power supply - but it is still essential to remove its +5V Enable Link and fit the Red/Blue +5V Supply lead as above. The output circuitry on the second ARCC will now operate in parallel with that on the first ARCC - ie. regardless of which ARCC is triggered by a passing train.

4.3 Sensor Cable Connections

The sensors are supplied ready-wired to their connecting cables and plugs but, if it is necessary to make up replacements (to accommodate landscaping requirements, for example), then details are given in Figure 5.

The leads of the emitter and detector should not be trimmed to less than 7mm from the body of the device, and soldering to the wires of the connecting cable should be done in the shortest time possible (consistent with making a reliable joint. Ensure that you observe the polarity of the devices as shown. Insulating sleeving over the joints is recommended to avoid short circuits as the sensors are manoeuvred into position.

Sensor Cable Connections

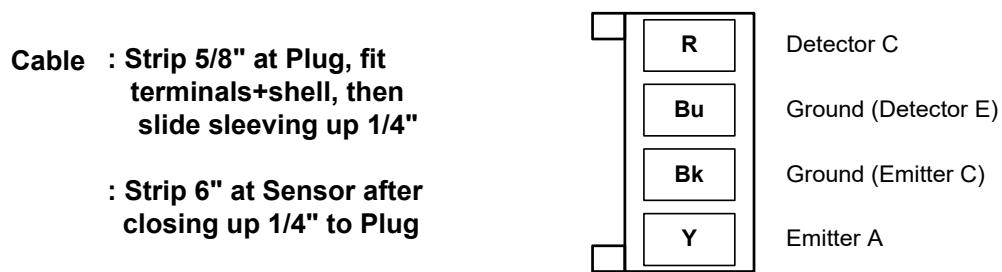

Sensor Connector - Top View

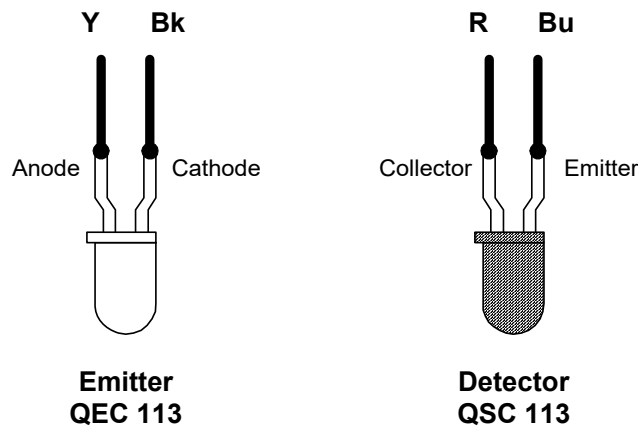

Figure 5

5 CIRCUIT DIAGRAM

The two sheets of the ARCC circuit diagram can be found as a separate insert at the back of this User Guide.

The ARCC consists of a number of functional blocks. Firstly, there are four identical circuit blocks each associated with one of the sensor assemblies A, B, C, and D. Secondly, there are two, almost identical, blocks of logic gates, each of which handles a pair of sensors - one for A and C, the other for D and B. Finally, there are the blocks to handle Reset, the output to the crossing signals, and to provide the ARCC circuitry with a stabilised 5 volt supply.

Looking at Sheet 1, Sensor Assembly A consists of the infra-red emitter LED1 (which is kept continuously on by the current through R1) and the phototransistor detector Q1. While the beam is intact, the light reaching Q1 makes it conduct fully, so that the voltage at the junction of R2 and the base of transistor Q2 is around 0.2 volts, keeping Q2 non-conducting. Resistors R3 and R4 will discharge capacitor C1 fully so that the inverting input (pin 6) to the comparator U1a will be at 0.0 volts. Since the comparator non-inverting input (pin 7) is held at 2.0 volts by the combination of resistors R5, R6, R7, and R8, the comparator output will be high (around 4.9 volts).

When beam A is interrupted, detector Q1 stops conducting and allows current through R2 to flow into the base of Q2, switching it on, and allowing current to flow through R4 and charge capacitor C1. As C1 charges, the voltage across it, and hence at the inverting input of U1a, rises. After about 15msec as the voltage reaches 2.0 volts, the comparator will trigger and bring its output low (close to 0.2 volts). Through R7 this also reduces the reference voltage at the comparator non-inverting input to around 1.1 volts, and so provides positive feedback to reinforce the switching of the comparator. Note that the purpose of using the slow-charging network of R4 and C1 is to reduce the chance of the comparator being triggered falsely by random electrical (or optical) interference.

Restoring beam A will return Q1 to a conducting state, drawing current through R2 and lowering the voltage at its collector (and hence at the base of Q2) to around 0.2 volts. This switches Q2 off and allows C1 to discharge again through R3 and R4. Once the voltage across C1 falls to the lowered reference level of 1.1 volts (this time after about 50 msec), comparator U1a will switch back to its original state with its output high at around 4.9 volts. Positive feedback via R7 returns the reference voltage to 2.0 volts, again reinforcing the switching of the comparator.

The circuit blocks for beams B, C, and D operate in exactly the same manner when their beams are interrupted. and the four comparator outputs provide the input signals to the logic blocks which control the activation of the crossing signals.

The block of logic on Sheet 1 handles control of the crossing where beam A is broken first. It consists principally of three latches (or flip-flops) LA, LC, and X, composed, respectively, of gates U2b and U3a, U2c and U3c, and, finally, U2d and U4c.

In the ARCC "Ready" state, with the outputs from comparators U1a (A-) and U1b (C-) at a 'high' level, all latch outputs (U2b6, U2c8, and U2d11) will be 'low' or inactive, ie. near GND or 0 volts.

As soon as beam 'A' is broken, the low output from comparator U1a1 applied to NAND gate U2b4 causes its output (U2b6 or LA) to go high. This high level is cross-coupled to gate U3a, making its output go low which, in turn, ensures that gate U2b stays with its output LA in the high state regardless of what happens to its input from the comparator U1a (signal A-). Latch

LA, therefore, records the fact that beam 'A' has been broken, and will stay in this state until it is deliberately reset.

Similarly, breaking beam 'C' switches latch LC (U2c and U3c) to its active state so, at this stage, the ARCC logic is aware that a train has passed through beams 'A' and 'C'. When the train is eventually clear of both beams, the outputs from both comparators (signals A- and C-) will return to a high state and, through NAND gates U4a and U3b, will reset both latches by applying low levels from the outputs of U4a and U3b to gates U3a and U3c, respectively. The logic is that LA is reset if LC is set and both beams are intact, and that LC is reset if LA is set and both beams are intact.

The third latch, X (U2d and U4c), is set by beam 'A' being broken, provided latch LC has NOT been set, by a low level signal on its input U2d12, via gates U5a and U4b. This latch effectively activates the crossing signals. Latch X is reset by the same signal which resets latch LA, ie. once the train has passed completely through beams 'A' and 'C'.

This simple logic ensures that there is no activation (by this logic block) by a train breaking beam 'C' before beam 'A', but requires the train to be completely beyond beam 'A' before everything is reset to the "Ready" state.

The three latches (and those of the similar logic block on Sheet 2) are all reset to their 'non-active' state by the Reset block also found on Sheet 1. When power is applied to the ARCC, capacitor C5 contains no charge, so both inputs of NAND gate U2a rise to VCC (+5 volts) and its output goes low to GND (0 volts). This low input to NAND gates U3a, U3c, and U4c ensures that their outputs go to a high state and, through the cross-coupling to the other halves of the latches (U2b, U2c, and U4c), ensures in turn that the outputs LA, LC, and X go to a low state (assuming that none of the beams are broken).

As C5 charges through resistor R34 it takes the inputs to U2a to a low state, returning the PON_RST- signal at the output of U2a to a high state, in which it has no further effect on any of the latches. A manual reset can be effected by pressing pushbutton SW1, which discharges C5 through resistor R33, and asserts the active-low PON_RST- signal again. Diode D1 protects the inputs of U2a from being reverse-biased by the voltage on C5 when power is switched off, and discharges C5.

The logic block on Sheet 2 operates with beams 'D' and 'B' in exactly the same way, with latches LD (U6b and U7a), LB (U6c and U7c), and Y (U6d and U8c). The output of latch Y (U6d11) is passed back to Sheet 1 and the input of NOR gate U5c. The output of U5c goes low when either of latches X or Y are set, and so provides the composite signal to drive the 'crossing active' output (TRACK1_X).

Before being applied finally to the output driver circuitry (on Sheet 2 again) the 'crossing active' signal can be logically 'ORed' with the 'crossing active' signal from another ARCC (the TRACK2_X signal) via gate U6a. Note that the Double Track Link fitted to the ARCC connects the TRACK1_X and TRACK2_X signals together when only a single ARCC is in use.

The final output signal, CROSS, is applied via inverting gate U5d to transistor Q9 which lights the Crossing Active LED (LED5) and drives the output power transistor Q10. Diode D2 protects Q10 from transient voltages when driving inductive loads such as relays or motors.

The final block on Sheet 1 shows a standard +5 Volt regulator, Q9, supplying all of the ARCC integrated circuits.

6 CIRCUIT BOARD CONSTRUCTION

Two sheets showing the stripboard (Veroboard) layout of the ARCC can be found as a separate insert at the back of this User Guide. There are also two sheets showing the layout of a minimum ARCC without power regulator and output circuitry, for use as a slave unit when operating with a dual-track crossing.

If undertaking construction of your own ARCC unit, the suggested order of building is as follows -

- (a) Cut all the stripboard tracks where indicated on the layout diagrams with a cross - note that the cross is dotted when the track cut lies under a component (so as not to obscure the component identity).
- (b) Fit all the wires to the top surface of the board - plain tinned copper wire is used (22 SWG, 21 AWG, or 0.7mm) - solder to the copper tracks, and trim all the protruding ends. A tip here, before you start, is to cut about 18 inches of wire from the reel, grip both ends with pliers, and stretch it until you just feel it 'give'. This should produce a nice straight piece of wire which will lie flat when cut and fitted to the board.
- (c) Next fit the passive components - resistors, capacitors, IC sockets (if required), and connectors - largest capacitors can be left until after step (d) to make the board easier to handle. Solder them in and trim off excess leads.
- (d) Now fit the active components - diodes, LED, bridge rectifier, and transistors. If you are not using IC sockets then you can now fit the ICs as well - taking anti-static precautions, of course - wear a properly-grounded wriststrap. Heatsinks are fitted to the relevant devices with an insulating washer - the heatsinks shown are connected to Ground. Usually it is easiest to fit the device to the heatsink first, then mount the complete assembly on the board.
- (e) Finally, run a small, sharp-bladed, flat screwdriver along each of the grooves between the copper tracks. This will remove any small short-circuits caused by solder splashes - and show up any larger shorts between tracks which need to be rectified.

After fitting any socketed ICs check that there are no shorts between ALL the power rails and Ground with an ohm-meter BEFORE applying power.

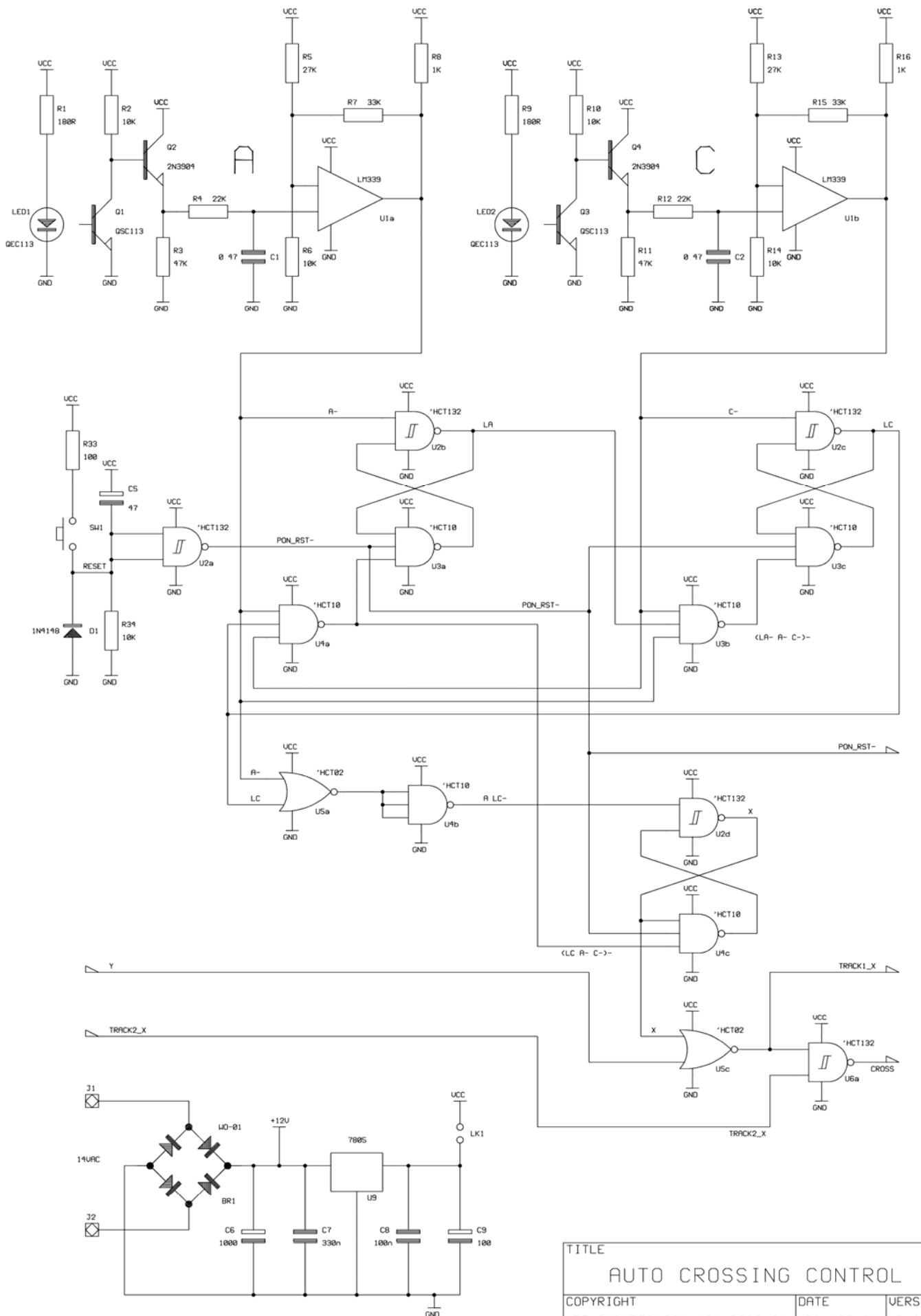

TITLE		
AUTO CROSSING CONTROL		
COPYRIGHT	DATE	VERSION
JT CHAMBERLAIN (C) 2000-01	03 MAR 01	2 4
REFERENCE	SHEET	
AUTCRS24 SCH	1 OF 2	

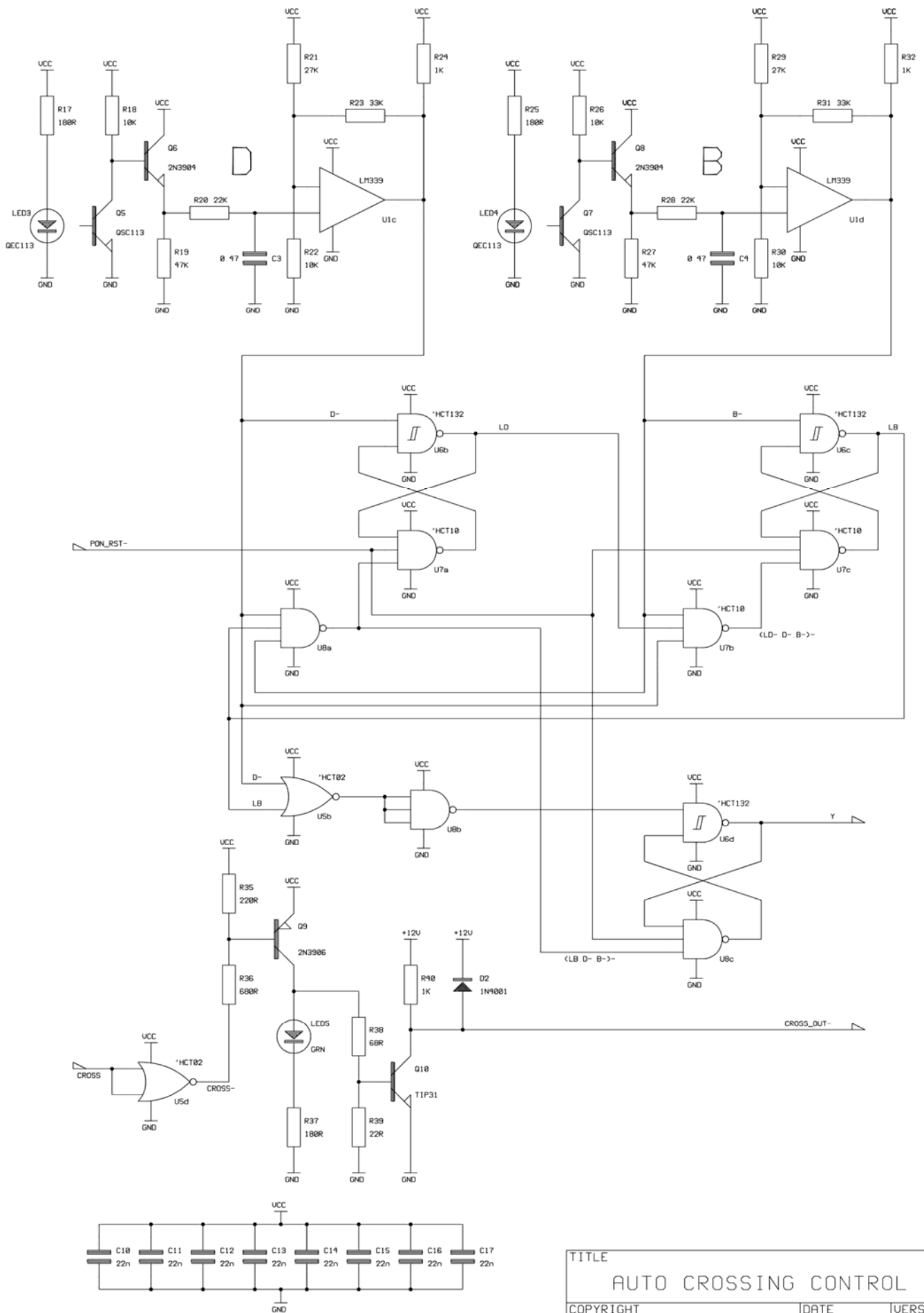

TITLE		
AUTO CROSSING CONTROL		
COPYRIGHT	DATE	VERSION
JT CHAMBERLAIN (C) 2000-01	03 MAR 01	2 4
REFERENCE	SHEET	
AUTCRS24 SCH	2 OF 2	

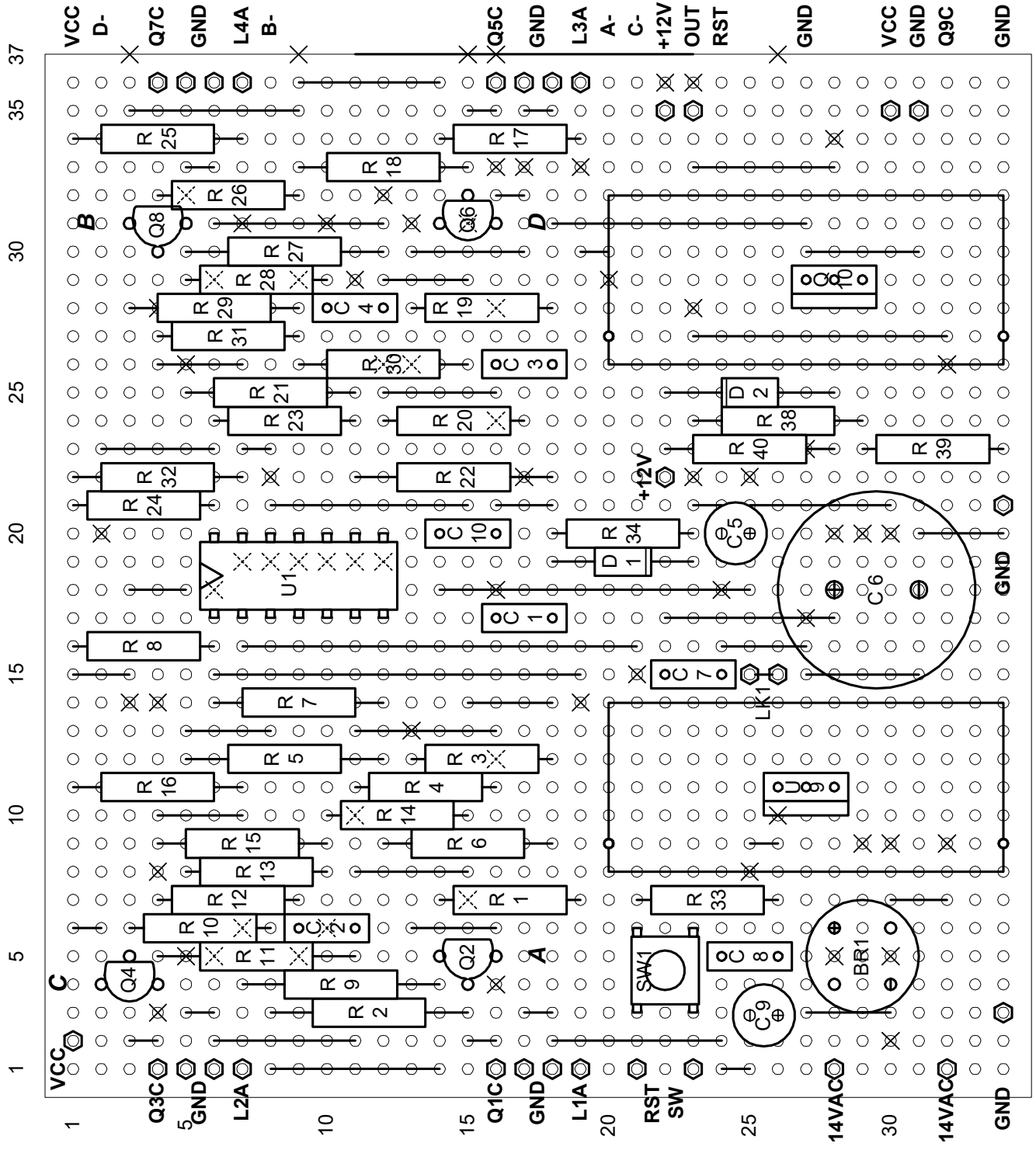

ARCC SENSORS & POWER - MASTER

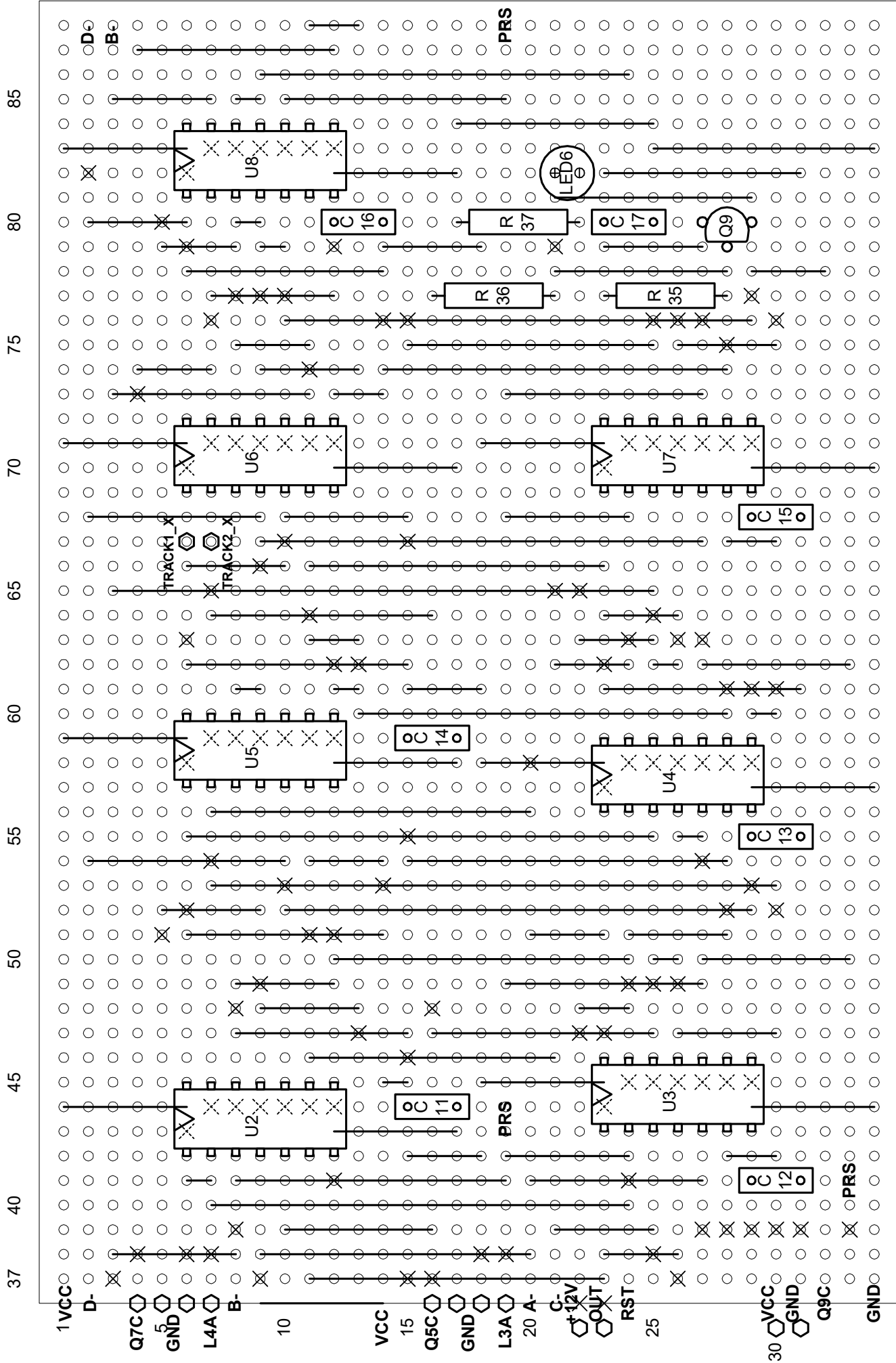

ARCC LOGIC - MASTER

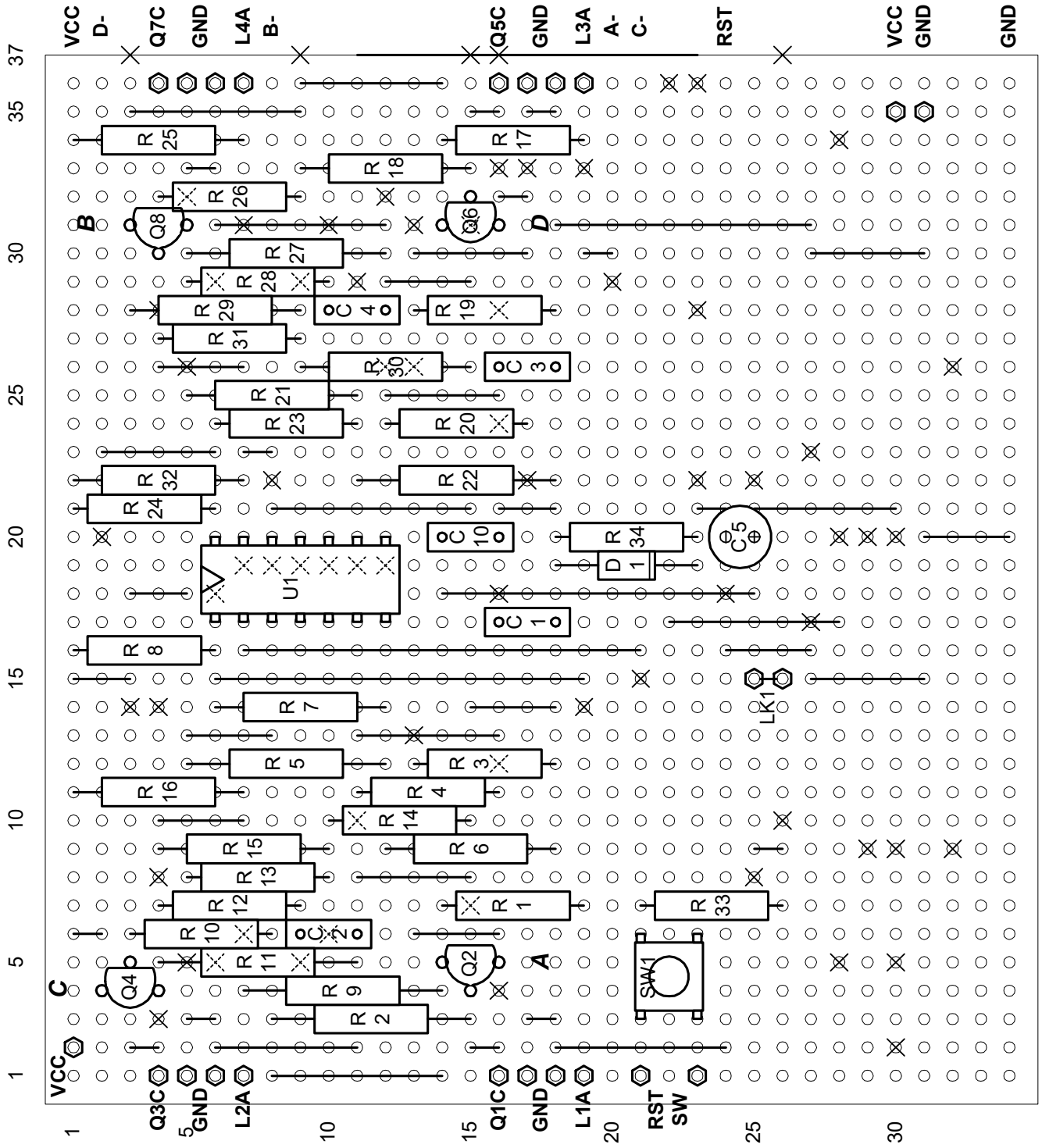

ARCC SENSORS & POWER - SLAVE

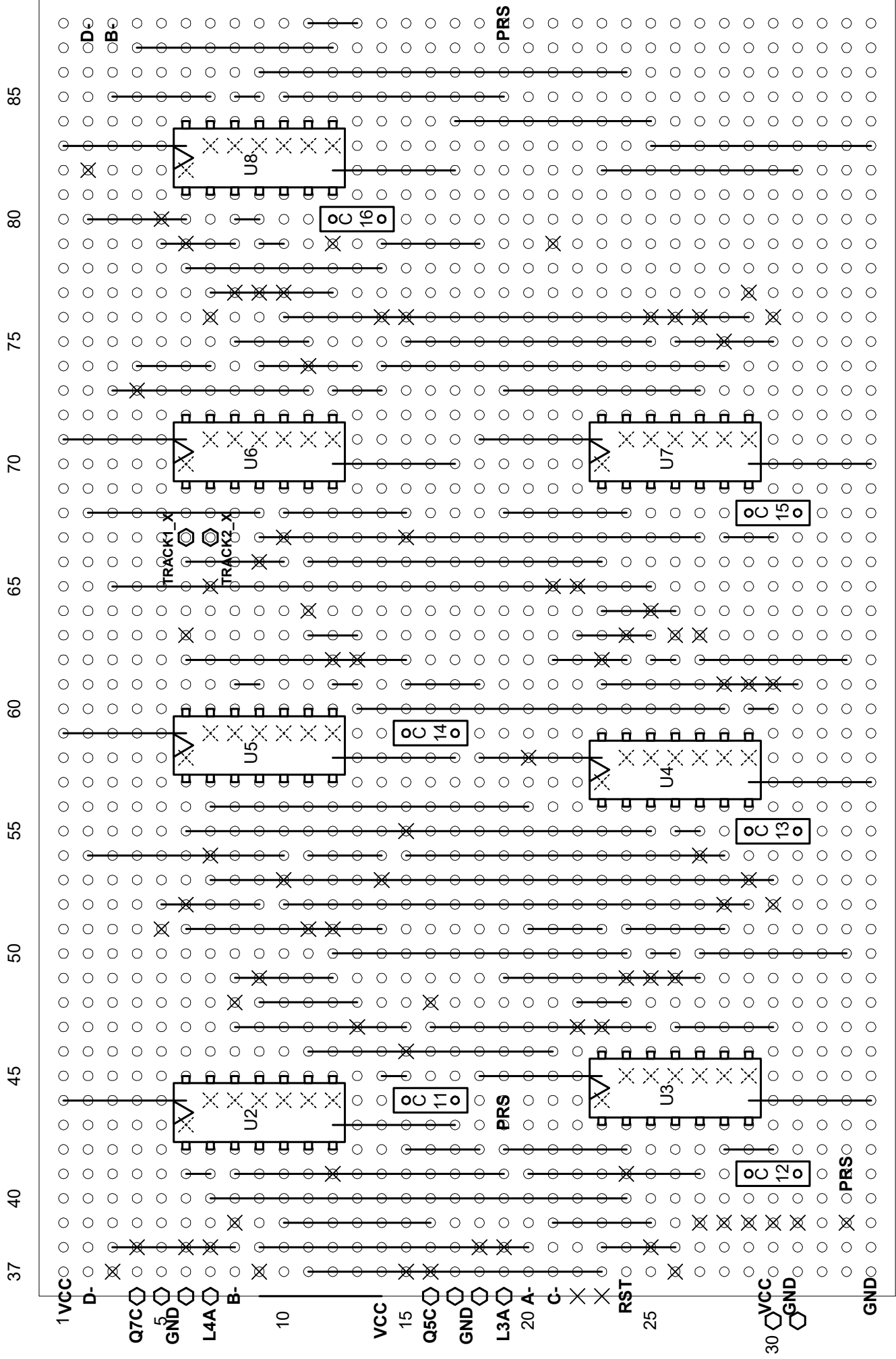

ARCC LOGIC - SLAVE